



BorgWarner to Begin First iDM Business in China

- *BorgWarner's first iDM business in China, to deliver innovative mobility solutions to Chinese customers*
- *The integrated drive module (iDM) combines state-of-the-art transmission technology, electric motor and power electronics in one package*
- *Company empowers global automakers to produce cleaner and more efficient vehicles*

Auburn Hill, Michigan, August 4, 2021 - BorgWarner, a global leader in delivering innovative and sustainable mobility solutions for the vehicle market, recently announced it will be supplying its iDM220 integrated drive module to a leading Chinese luxury New Energy Vehicle (NEV) brand. After the recent award of an iDM for a Korean customer, this is now the first business in China, continuing our success with the BW iDM technology. The start of production for this business will be in Q1 2023.

Designed, developed and manufactured by BorgWarner, the iDM220 is a high-performance electric drive system. Operating at 400V, it also addresses upcoming market needs and allows for performance upgrades. The solution combines high-efficiency motor-controller technology with BorgWarner's award-winning hairpin stator winding technology and advanced transmission system in a scalable, compact package that empowers global automakers to produce cleaner and more efficient vehicles.

"We are pleased to extend our long-standing partnership with this leading Chinese luxury NEV brand by supplying them with our industry leading iDM," said Dr. Stefan Demmerle, President and General Manager, BorgWarner PowerDrive Systems. "Our new iDM is expected to power smart, innovative and future-proof mobility solutions for our customers. In the carbon neutrality context, we will continue to develop clean and powerful solutions like the iDM220 and work even more seamlessly with our customers toward an eco-friendly future."

Mounted on the rear drive, the iDM220 will provide up to 250 kW of power and 5000 Nm of torque. The advanced electric drive product offers a high degree of integration, high efficiency and smooth and quiet operation, while also delivering exceptional performance through its hairpin-wound stator motor technology. The iDM incorporates an electric motor with a compact stator with an outer diameter of 220 mm, and integrates a gearbox and 400V silicon-based inverter, significantly reducing the weight and size of the entire system. All of the components used in the iDM are part of

BorgWarner's technology portfolio and available either as a fully integrated module or as stand-alone solutions for new energy vehicles.

About BorgWarner

BorgWarner Inc. (NYSE: BWA) is a global product leader in delivering innovative and sustainable mobility solutions for the vehicle market. Building on its original equipment expertise, BorgWarner also brings market leading product and service solutions to the global aftermarket. With manufacturing and technical facilities in 96 locations in 23 countries, the company employs approximately 50,000 people worldwide. For more information, please visit borgwarner.com.

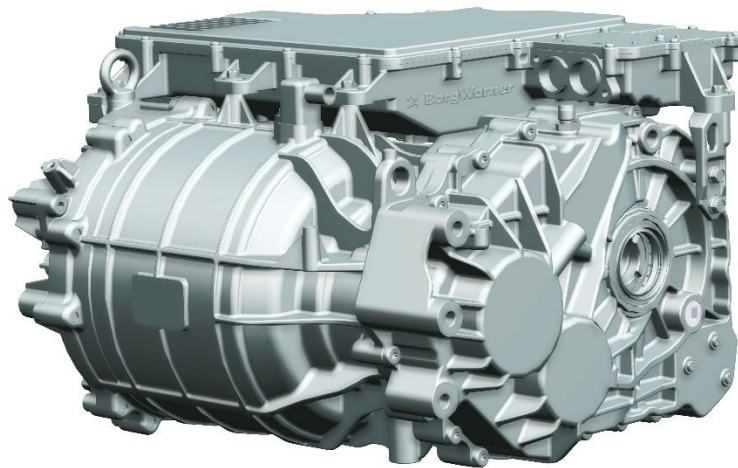

BorgWarner to begin first iDM business in China

Forward-Looking Statements: This press release may contain forward-looking statements as contemplated by the 1995 Private Securities Litigation Reform Act that are based on management's current outlook, expectations, estimates and projections. Words such as "anticipates," "believes," "continues," "could," "designed," "effect," "estimates," "evaluates," "expects," "forecasts," "goal," "guidance," "initiative," "intends," "may," "outlook," "plans," "potential," "predicts," "project," "pursue," "seek," "should," "target," "when," "will," "would," and variations of such words and similar expressions are intended to identify such forward-looking statements. Further, all statements, other than statements of historical fact contained or incorporated by reference in this press release that we expect or anticipate will or may occur in the future regarding our financial position, business strategy and measures to implement that strategy, including changes to operations, competitive strengths, goals, expansion and growth of our business and operations, plans, references to future success and other such matters, are forward looking statements. Accounting estimates, such as those described under the heading "Critical Accounting Policies and Estimates" in Item 7 of our Annual Report on Form 10-K for the year ended December 31, 2020 ("Form 10-K"), are inherently forward-looking. All forward-looking statements are based on assumptions and analyses made by us in light of our experience and our perception of historical trends, current conditions and expected future developments, as well as other factors we believe are appropriate in the circumstances. Forward-looking statements are not guarantees of performance, and the Company's actual results may differ materially from those expressed, projected or implied in or by the forward-looking statements.

You should not place undue reliance on these forward-looking statements, which speak only as of the date of this press release. Forward-looking statements are subject to risks and uncertainties, many of which are difficult to predict and generally beyond our control, that could cause actual results to differ materially from those expressed, projected or implied in or by the forward-looking statements. These risks and uncertainties, among others, include: the difficulty in forecasting margin performance and free cash flow through 2025 in light of the variables that can impact those results over that period of time; the difficulty in forecasting demand for electric vehicles and our EV revenue growth by 2030, which is long term; margin performance and free cash flow through 2025; the ability to identify targets and consummate acquisitions on acceptable terms; failure to realize the expected benefits of acquisitions; the ability to identify appropriate combustion portfolio businesses for disposition and consummate planned dispositions on acceptable terms; competition competitive challenges from existing and new competitors including from OEMs customers; the challenges associated with rapidly-changing technologies, particularly as relates to electric vehicles, and our ability to innovate in response; the ability to innovate; uncertainties regarding the extent and duration of impacts of matters associated with COVID-19, including additional production disruptions; the failure to realize the expected benefits of the acquisition of Delphi Technologies PLC that the Company completed on October 1, 2020; the failure to promptly and effectively integrate acquired businesses; the potential for unknown or inestimable liabilities relating to the acquired businesses; the possibility that the proposed transaction between the Company and AKASOL AG will not be consummated; failure to obtain necessary regulatory approvals or to satisfy any of the other conditions to the proposed transaction; failure to realize the expected benefits of the proposed transaction; our dependence on automotive and truck production, both of which are highly cyclical and subject to disruptions; our reliance on major OEM customers; commodities availability and pricing; supply disruptions; fluctuations in interest rates and foreign currency exchange rates; availability of credit; our dependence on key management; our dependence on information systems; the uncertainty of the global economic environment; the outcome of existing or any future legal proceedings, including litigation with respect to various claims; future changes in laws and regulations, including, by way of example, tariffs, in the countries in which we operate; impacts from any potential future acquisition or divestiture transactions; and the other risks noted in reports that we file with the Securities and Exchange Commission, including Item 1A, "Risk Factors" in our most recently-filed Form 10-K. We do not undertake any obligation to update or announce publicly any updates to or revisions to any of the forward-looking statements in this press release to reflect any change in our expectations or any change in events, conditions, circumstances, or assumptions underlying the statements.

PR contact:

Michelle Collins

Phone: +1 248-754-0449

Email: mediacontakt@borgwarner.com